

Tutorial 7: Using the Lathe Workshop

Topics Covered:

- Lathe Workshop
- Pen tool- Bezier Curves
- Points- Corner and Curve
- Complex Cross-sections of Lathe Objects

Objective: To create a candlestick with a complex cross-section, while becoming familiar with two different types of points on bezier curves.----SAVE OFTEN!!!! (after each major step)

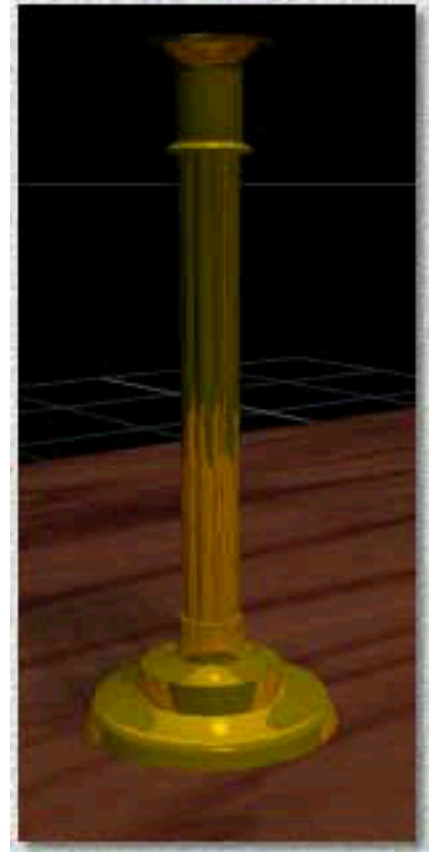

I. Creating the Object

1. Use the WINEGLASS tool to place a Lathe object at the center of the world.
2. Choose EDIT OBJECT from the OBJECT menu. This will take the object into the LATHE workshop. You should see an outline of the object, centered around the vertical and horizontal axes, as if the glass had been sliced in half. This is the lathe profile, or outline.
3. Choose the ARROW tool from the TOOLS floater. Click the outline. Notice the outline is made from points connected by curved or straight lines. Click and drag to select all the points on the outline. Delete the outline, using CLEAR from the EDIT menu. Choose ENDCAPS- NONE from the OBJECT menu. The front view window should now be empty.
4. Choose the PEN tool from the TOOLS floater.
---The most important thing to remember in the Lathe workshop is that everything you draw must stay to one side of the vertical axis. For the purposes of this tutorial, all outlines will be drawn to the right of the vertical axis, and will automatically be mirrored on the opposite side.---
5. First, we want to create the top portion of the candlestick. Start by looking at the outline of the top section.

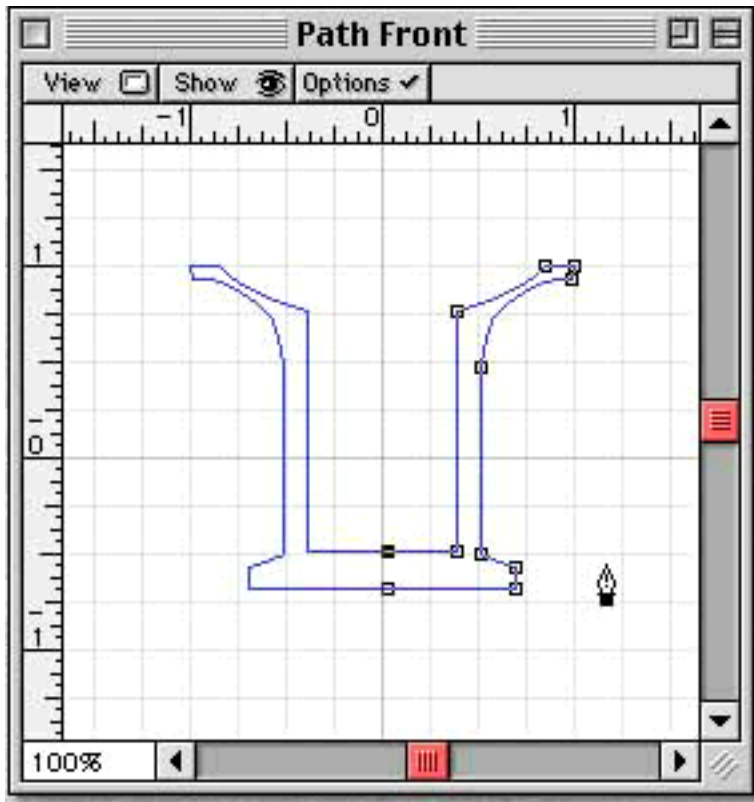

Notice the relationships between the curves and straight lines which make up the outline. For each major change in the shape of the outline, you will need to place points to create curve or line. As we see in the screen shot, we have eleven major shape changes, so we will have eleven points on our outline. The points are placed in the order shown:

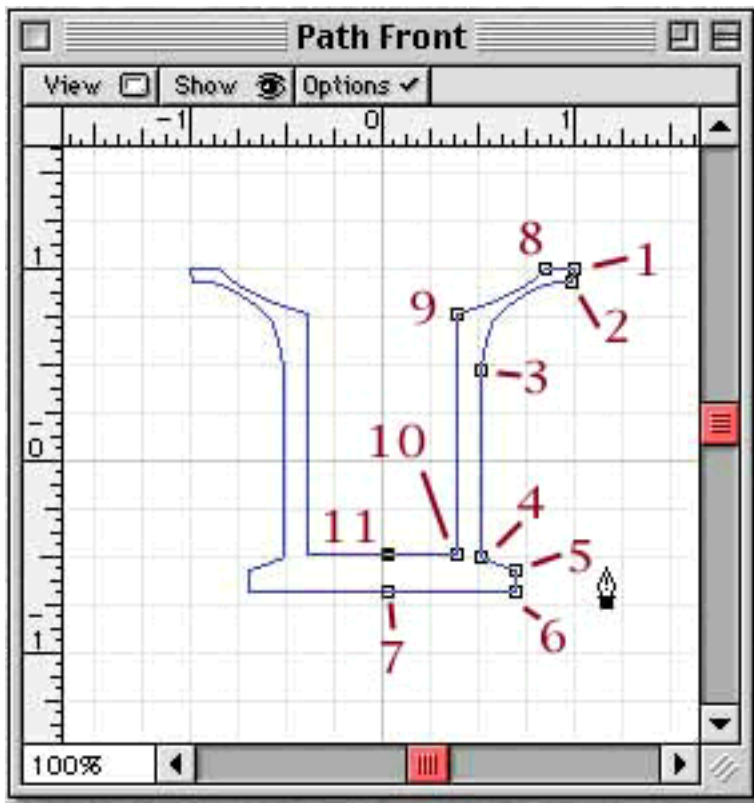

-Anytime you wish to add a line/point to the outline, to continue where you left off, make sure that the previous point

is selected. Then, click and drag to create the next curve.-

6. Create the outline for the top of the candlestick, placing points in the order shown in the previous diagram.

6a. Use the PEN tool to place the first point at one inch to the right of the vertical axis and one inch above the horizontal axis (1,1).

6b. Place the second point 1/8 inch directly below the first point. Use the arrow keys to nudge it into place if needed.

6c. Place the third point at 1/2, 1/2 (to the right of the vertical axis and above the horizontal axis).

6d. Place the fourth point at -1/2 inch (below the horizontal axis), and 1/2 inch, directly below the previous point.

6e. Select the third point by clicking it. Choose CORNER from the POINTS menu. This changes the type of point, allowing the lines on either side of the point to be manipulated independently, without effecting any other curves or lines. Grab the top handle and drag until a nice arc is created, with the handle about even with the top of the outline.

6f. Select the fourth point. Place the fifth point at a 60 degree angle, 1/4 inch to the right.

6g. Place the 6th point directly below the fifth at -3/4 inches (below the horizontal axis).

6h. Place the 7th point at the center vertical axis, straight across from the previous point. You may have to CORNER the 6th point to keep the corner at a 90 degree angle.

6i. Select the first point. Create point 8 by clicking almost 1/4 inch toward the vertical axis.

6j. Place the 9th point just inside the outer outline, at 3/8, 1/2 inches, even with the third point. Drag the handle to make a shallow, concave curve. Be careful to not intersect with the outer outline.

6k. Place the 10th point directly below the 9th at -1/2 inch (below horizontal). Select the previous point (9) and choose CORNER from the POINTS menu, Grab the left handle and pull down until the line between 9 and 10 is straight.

6l. Place the 11th point at the center vertical axis, directly horizontal with the 10th point.

6m. Exit the workshop. The top of the candlestick is complete.

7. The bottom object is created using the same technique. Place a new lathe object at the same coordinates as the top object (you can use the INFO floater to do this).

7a. Figure out how many points are needed to create the bottom outline.

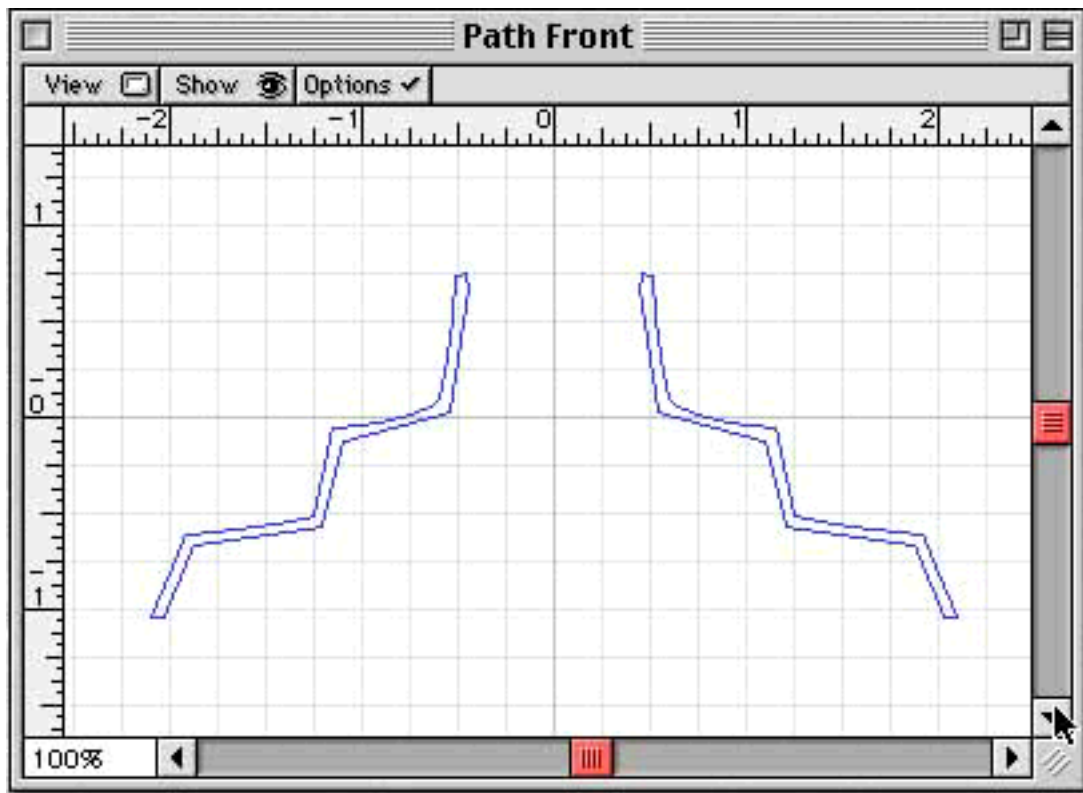

7b. Place point 1 at 1/2, 3/4 inch. Follow the diagram to place the rest of the points, CORNERING the points where necessary to straighten unwanted curves.

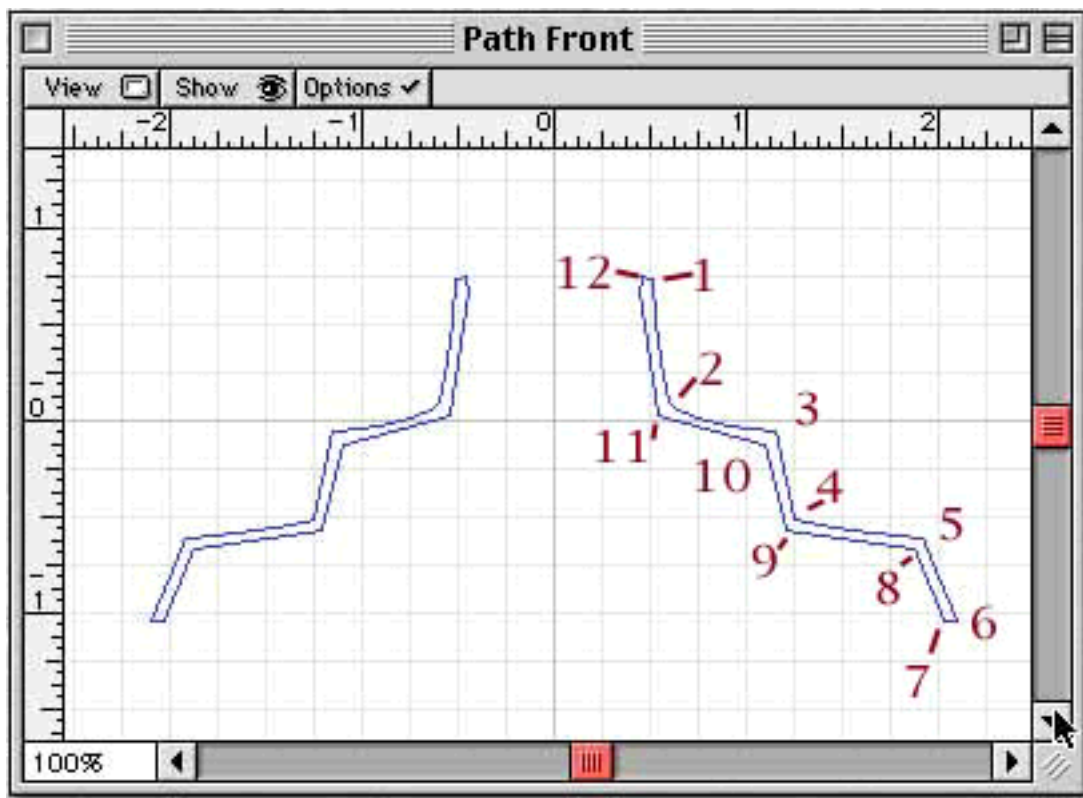

8. Next, we will create the center section of the candlestick. Place a new lathe object at the same coordinates as the previous objects. We will modify the cross-section of the lathe object to produce a fluted pillar. Choose EDIT OBJECT from the OBJECT menu.

8a. Create the object outline by placing a straight line (2 points) at 1/2 inch right of the vertical axis, starting at 3 3/4 and ending at -3 3/4 inches. Choose ENDCAPS- BOTH from the OBJECT menu.

8b. Open the CROSS SECTION window from the WINDOWS menu.

8.c Choose the POLYGON tool from the TOOLS floater. Double-click it to bring up a dialog box. In the POLY SIDES box, enter 20, for the number of sides, and hit the OKAY button.

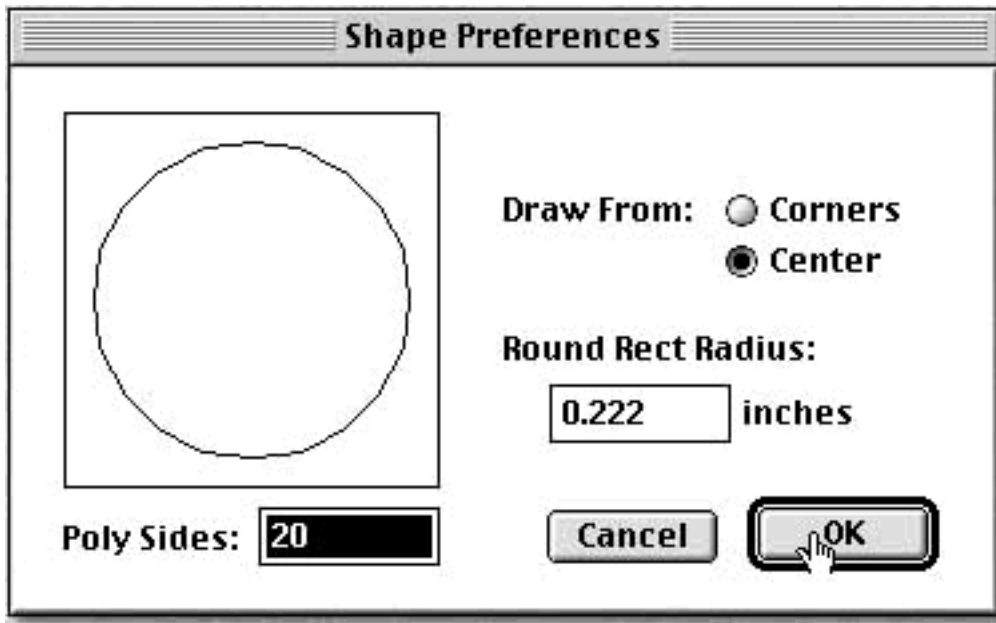

8d. Holding down the SHIFT key, click at the center of the current cross section (a circle) and drag outwards until the new outline closely matches the old in diameter. Release the mouse button. Select the original outline and delete it.

8e. Select the point just to the right of the top-most point along the circle outline, and drag it so that the outline is indented, keeping the point evenly between the points to either side. Do this to every other point until a star-like circle outline is formed.

8f. Select the top-most point and choose CURVE from the POINTS menu. Repeat this for each peak until a flower shaped outline is seen in the window.

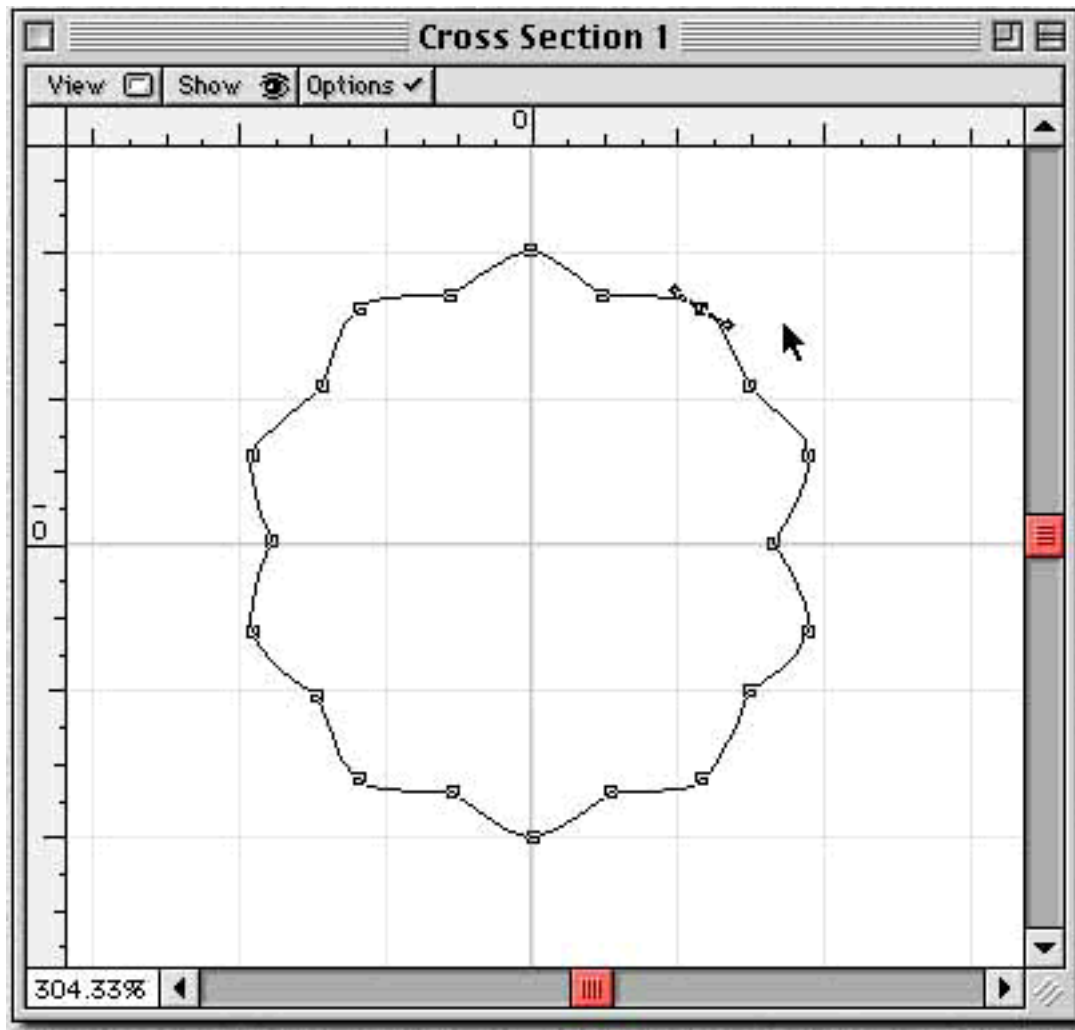

8g. Exit the workshop.

9. Move the CAMERA so the entire candlestick can be seen in the view window (do not use the ZOOM tool in the camera window-- it messes up the focal length of the camera and is difficult to correct). Select the CAMERA and make the TOP view active. Drag the CAMERA away from the objects.

10. Select the top object. Open the INFO floater. In the Z coordinate box, type 4.508 and hit the ENTER or RETURN key.

11. Select the bottom object, making sure that the X and Y coordinates are the same as the top object. Enter -4.508 in the Z box.

12. Select the center section and place it at the same X and Y coordinates. Enter 0.340 in the Z box.

13. Set surface of the objects by choosing one of the stock textures or create your own.

The Candlestick is ready to be placed in a scene.

[\[Home\]](#) [\[Who I am and What I do.\]](#) [\[New Gallery 3D!\]](#) [\[New Gallery 2D!\]](#) [\[Tutorial Page\]](#) [\[Tips and Articles\]](#) [\[Cool Links!\]](#) [\[Old Gallery 3D\]](#) [\[Old Gallery 2D\]](#) [\[Bug Report Page--includes fixes\]](#) [\[Feedback\]](#)

All images and tutorials are ©Jennifer Nieland, 1996-97; Iowa State University. Please write for permission to re-use or redistribute images or tutorials.