

2-D stresses, traction vector

2-D (biaxial) state of stress

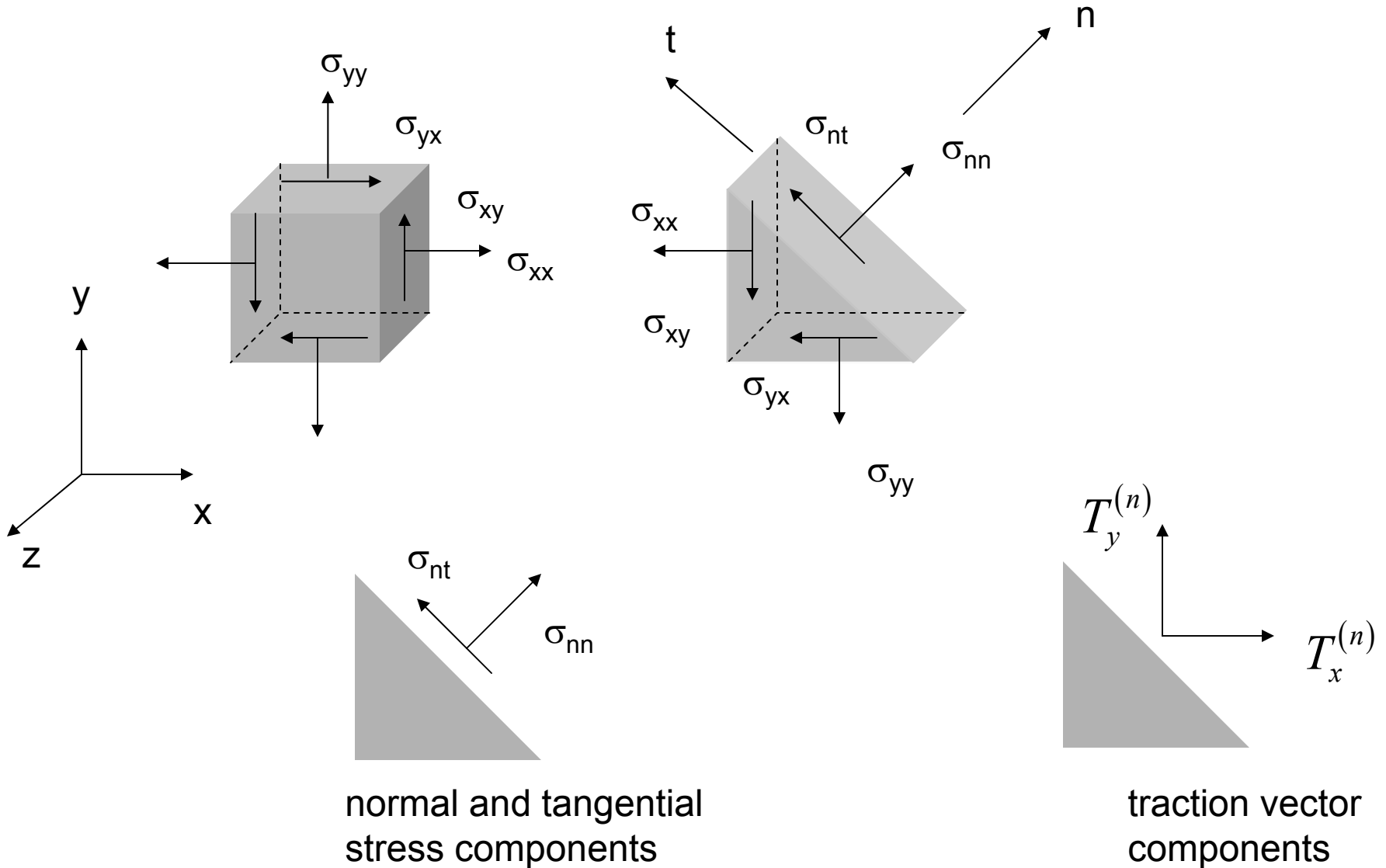

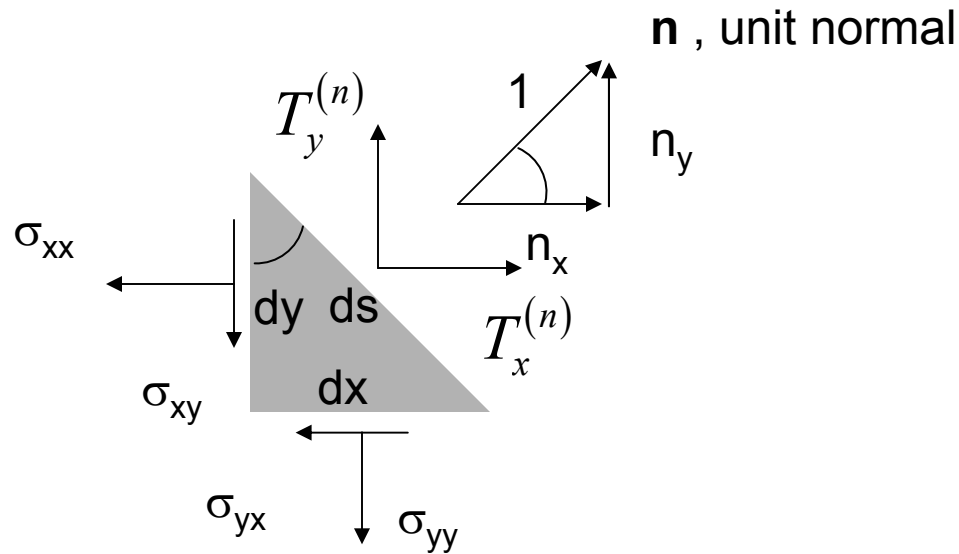

$$\sum F_x = 0 \quad \Rightarrow \quad T_x^{(n)} ds dz - \sigma_{xx} dy dz - \sigma_{yx} dx dz = 0$$

$$T_x^{(n)} = \sigma_{xx} \frac{dy}{ds} + \sigma_{yx} \frac{dx}{ds}$$

$$T_x^{(n)} = \sigma_{xx} n_x + \sigma_{yx} n_y$$

similarly

$$\sum F_y = 0 \quad \Rightarrow \quad T_y^{(n)} = \sigma_{xy} n_x + \sigma_{yy} n_y$$

$$T_x^{(n)} = \sigma_{xx} n_x + \sigma_{yx} n_y$$

$$T_y^{(n)} = \sigma_{xy} n_x + \sigma_{yy} n_y$$

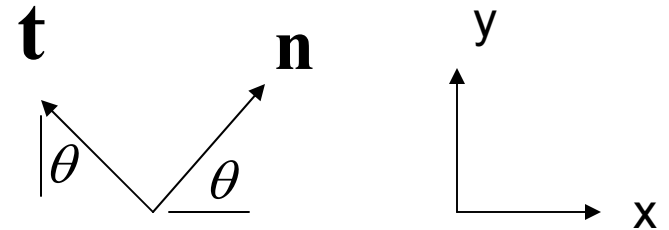
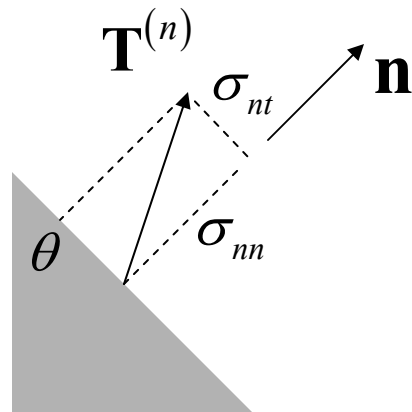
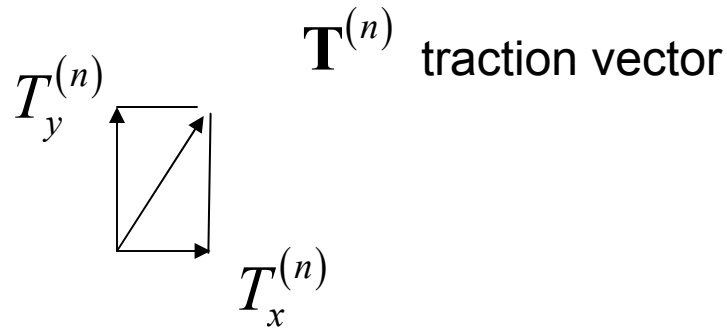

$$\begin{aligned} \sigma_{nn} &= \mathbf{T}^{(n)} \cdot \mathbf{n} = T_x^{(n)} n_x + T_y^{(n)} n_y \\ &= \sigma_{xx} n_x^2 + \sigma_{yy} n_y^2 + 2\sigma_{xy} n_x n_y \\ &= \sigma_{xx} \cos^2 \theta + \sigma_{yy} \sin^2 \theta + 2\sigma_{xy} \sin \theta \cos \theta \end{aligned}$$

$$\begin{aligned} \sigma_{nt} &= \mathbf{T}^{(n)} \cdot \mathbf{t} = T_x^{(n)} t_x + T_y^{(n)} t_y \\ &= \sigma_{xx} n_x t_x + \sigma_{yy} n_y t_y + \sigma_{xy} (n_x t_y + n_y t_x) \\ &= -\sigma_{xx} \cos \theta \sin \theta + \sigma_{yy} \sin \theta \cos \theta + \sigma_{xy} (\cos^2 \theta - \sin^2 \theta) \end{aligned}$$

$$T_x^{(n)} = \sigma_{xx} n_x + \sigma_{yx} n_y$$

$$T_y^{(n)} = \sigma_{xy} n_x + \sigma_{yy} n_y$$

$$\sigma_{nn} = \sigma_{xx} n_x^2 + \sigma_{yy} n_y^2 + 2\sigma_{xy} n_x n_y$$

$$\sigma_{nt} = \sigma_{xx} n_x t_x + \sigma_{yy} n_y t_y + \sigma_{xy} (n_x t_y + n_y t_x)$$

principal stresses, planes

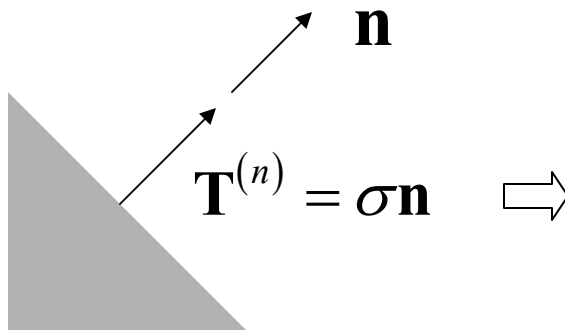

$$\sigma_{xx} n_x + \sigma_{yx} n_y = \sigma n_x$$

$$\sigma_{xy} n_x + \sigma_{yy} n_y = \sigma n_y$$

or $(\sigma_{xx} - \sigma) n_x + \sigma_{yx} n_y = 0$

$$\sigma_{xy} n_x + (\sigma_{yy} - \sigma) n_y = 0$$

principal stresses, principal planes

eigenvalue problem

$$(\sigma_{xx} - \sigma)n_x + \sigma_{xy}n_y = 0$$

$$\sigma_{xy}n_x + (\sigma_{yy} - \sigma)n_y = 0$$

$$\begin{bmatrix} \sigma_{xx} & \sigma_{xy} \\ \sigma_{yx} & \sigma_{yy} \end{bmatrix} \rightarrow \begin{bmatrix} \sigma_{p1} & 0 \\ 0 & \sigma_{p2} \end{bmatrix}$$

eigenvalues (principal stresses)

y

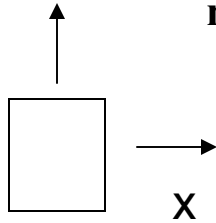

$$\mathbf{n}^{(2)} = \{n_x^{(2)}, n_y^{(2)}\}$$

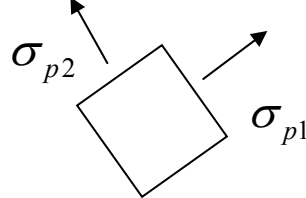

eigenvectors (principal directions)

$$\mathbf{n}^{(1)} = \{n_x^{(1)}, n_y^{(1)}\}$$

principal stresses, principal planes

$$(\sigma_{xx} - \sigma)n_x + \sigma_{xy}n_y = 0$$

$$\sigma_{xy}n_x + (\sigma_{yy} - \sigma)n_y = 0$$

These homogeneous equations have a non-trivial solution only if

$$\begin{vmatrix} (\sigma_{xx} - \sigma) & \sigma_{xy} \\ \sigma_{xy} & (\sigma_{yy} - \sigma) \end{vmatrix} = 0$$

$$\sigma^2 - I_1\sigma + I_2 = 0$$

$$I_1 = \sigma_{xx} + \sigma_{yy}$$

$$I_2 = \sigma_{xx}\sigma_{yy} - \sigma_{xy}^2$$

stress invariants

$$\sigma^2 - I_1\sigma + I_2 = 0$$

$$I_1 = \sigma_{xx} + \sigma_{yy} = \sigma_{p1} + \sigma_{p2}$$

$$I_2 = \sigma_{xx}\sigma_{yy} - \sigma_{xy}^2 = \sigma_{p1}\sigma_{p2}$$

two roots:

$$\begin{aligned} \sigma_{p1}, \sigma_{p2} &= \frac{I_1}{2} \pm \sqrt{\frac{I_1^2}{4} - I_2} \\ &= \frac{\sigma_{xx} + \sigma_{yy}}{2} \pm \sqrt{\left(\frac{\sigma_{xx} - \sigma_{yy}}{2}\right)^2 + \sigma_{xy}^2} \end{aligned}$$

To find the two principal directions, for each principal stress solve one of the equations

$$(\sigma_{xx} - \sigma)n_x + \sigma_{xy}n_y = 0$$

$$\sigma_{xy}n_x + (\sigma_{yy} - \sigma)n_y = 0$$

$$\sigma = \sigma_{p1}, \sigma_{p2}$$

for $\frac{n_x}{n_y}$ with $n_x^2 + n_y^2 = 1$

Principal Stresses with MATLAB

```
>> stress = [ 10 -4 ; -4 6]
```

```
stress =
```

```
    10    -4  
    -4     6
```

```
>> [pdirs, pstress] = eig(stress)
```

```
pdirs =
```

```
 -0.5257 -0.8507  
 -0.8507  0.5257
```

```
pstress =
```

```
  3.5279     0  
     0 12.4721
```

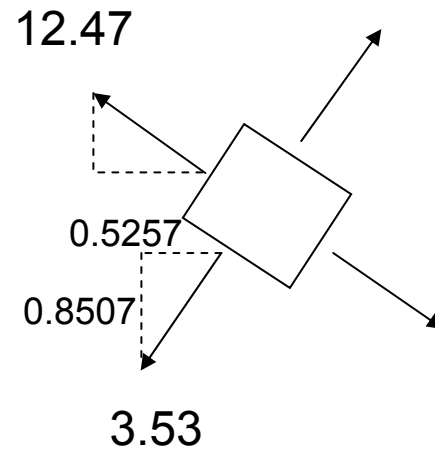

Principal stresses directly

$$(10 - \sigma)n_x - 4n_y = 0$$

$$-4n_x + (6 - \sigma)n_y = 0$$

$$I_1 = 16$$

$$I_2 = 44$$

$$\sigma^2 - 16\sigma + 44 = 0$$

roots are 3.5279, 12.4721

Try 3.5279

$$6.4721n_x - 4n_y = 0$$

$$-4n_x + 2.4721n_y = 0$$

From the first equation $\frac{n_x}{n_y} = 0.618$ (second equation gives same)

$$\frac{n_x^2}{n_y^2} + 1 = \frac{1}{n_y^2} \implies \begin{aligned} n_y &= \pm 0.8506 \\ n_x &= \pm 0.5257 \end{aligned}$$

similarly the second principal stress direction is obtained

```
>> stress3D = [ 10 -4 0;
               -4  6 0;
               0  0 0]
```

```
stress3D =
```

```
10  -4  0
-4   6  0
 0   0  0
```

```
>> [pdirs, pstress] = eig(stress3D)
```

```
pvdirs =
```

```
 0 -0.5257 -0.8507
 0 -0.8507  0.5257
 1.0000  0  0
```

```
pstress =
```

```
 0  0  0
 0 3.5279  0
 0  0 12.4721
```

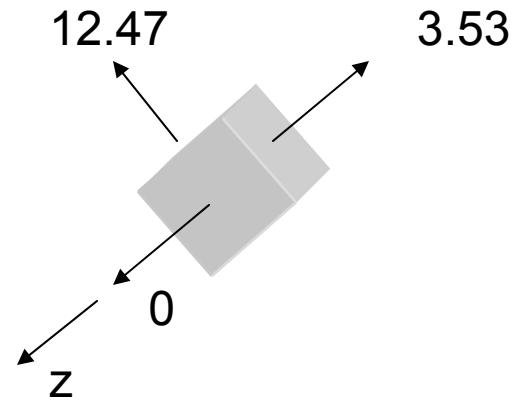
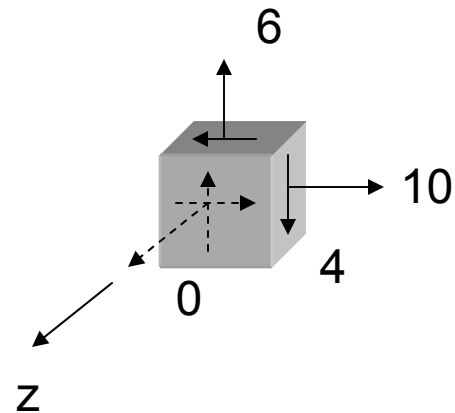

$$T_x^{(n)} = \sigma_{xx} n_x + \sigma_{yx} n_y$$

$$T_y^{(n)} = \sigma_{xy} n_x + \sigma_{yy} n_y$$

In vector/matrix form

$$\begin{Bmatrix} T_x^{(n)} \\ T_y^{(n)} \end{Bmatrix} = \begin{Bmatrix} n_x & n_y \end{Bmatrix} \begin{bmatrix} \sigma_{xx} & \sigma_{xy} \\ \sigma_{yx} & \sigma_{yy} \end{bmatrix}$$

MATLAB

```
>> stress = [40 -20;
             -20, 50];
```

```
>> norm = [0.6 0.8];
```

```
>> tract = norm*stress
tract =
```

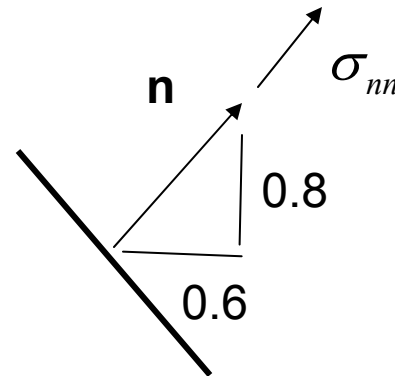

$$\sigma_{nn} = T_x^{(n)} n_x + T_y^{(n)} n_y$$

$$\sigma_{nn} = \sigma_{xx} n_x^2 + \sigma_{yy} n_y^2 + 2\sigma_{xy} n_x n_y$$

vector/matrix form

$$\sigma_{nn} = \begin{Bmatrix} T_x^{(n)} & T_y^{(n)} \end{Bmatrix} \begin{Bmatrix} n_x \\ n_y \end{Bmatrix}$$

$$\sigma_{nn} = \begin{Bmatrix} n_x & n_y \end{Bmatrix} \begin{bmatrix} \sigma_{xx} & \sigma_{xy} \\ \sigma_{yx} & \sigma_{yy} \end{bmatrix} \begin{Bmatrix} n_x \\ n_y \end{Bmatrix}$$

MATLAB

```
>> normstress = tract*norm'
```

```
normstress =
```

```
27.2000
```

```
>> normstress2 = norm*stress*norm'
```

```
normstress2 =
```

```
27.2000
```

$$\sigma_{nt} = \sigma_{xx} n_x t_x + \sigma_{yy} n_y t_y + \sigma_{xy} (n_x t_y + n_y t_x)$$

$$\sigma_{nt} = T_x^{(n)} t_x + T_y^{(n)} t_y$$

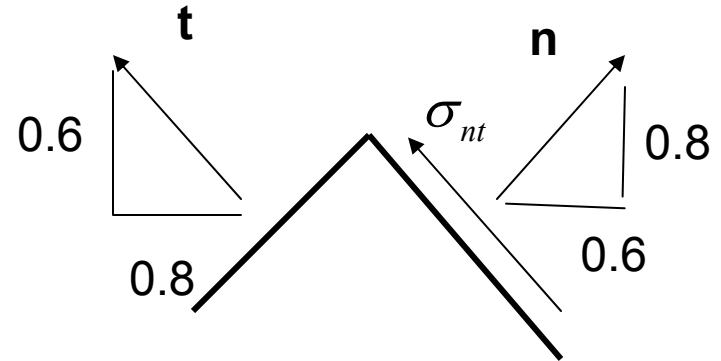

vector/matrix form

$$\sigma_{nt} = \begin{Bmatrix} T_x^{(n)} & T_y^{(n)} \end{Bmatrix} \begin{Bmatrix} t_x \\ t_y \end{Bmatrix} \quad \sigma_{nt} = \begin{Bmatrix} n_x & n_y \end{Bmatrix} \begin{bmatrix} \sigma_{xx} & \sigma_{xy} \\ \sigma_{yx} & \sigma_{yy} \end{bmatrix} \begin{Bmatrix} t_x \\ t_y \end{Bmatrix}$$

```
MATLAB >> tang = [-0.8 0.6];
>> tang*norm'
ans = 0
```

```
>> shearstress = tract*tang'
shearstress = 10.4000
```

```
>> shearstress2 = norm*stress*tang'
shearstress2 =
10.4000
```

$$\sigma_{nn} = \begin{Bmatrix} n_x & n_y \end{Bmatrix} \begin{bmatrix} \sigma_{xx} & \sigma_{xy} \\ \sigma_{yx} & \sigma_{yy} \end{bmatrix} \begin{Bmatrix} n_x \\ n_y \end{Bmatrix}$$

$$\sigma_{nt} = \begin{Bmatrix} n_x & n_y \end{Bmatrix} \begin{bmatrix} \sigma_{xx} & \sigma_{xy} \\ \sigma_{yx} & \sigma_{yy} \end{bmatrix} \begin{Bmatrix} t_x \\ t_y \end{Bmatrix}$$

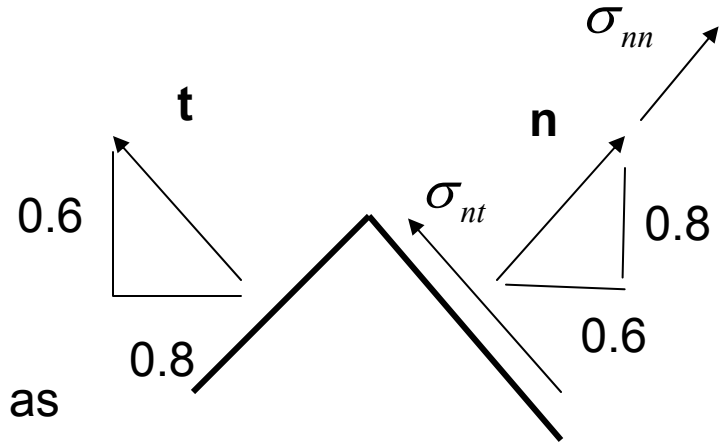

we can put these together in vector/matrix form as

$$\begin{Bmatrix} \sigma_{nn} & \sigma_{nt} \end{Bmatrix} = \begin{Bmatrix} n_x & n_y \end{Bmatrix} \begin{bmatrix} \sigma_{xx} & \sigma_{xy} \\ \sigma_{yx} & \sigma_{yy} \end{bmatrix} \begin{bmatrix} n_x & t_x \\ n_y & t_y \end{bmatrix}$$

MATLAB

```
>> dirs =[norm' tang']
```

```
dirs =
```

```
0.6000 -0.8000
```

```
0.8000 0.6000
```

```
>> stresses_on_n = norm*stress*dirs
```

```
stresses_on_n =
```

```
27.2000 10.4000
```

traction on plane whose normal is \mathbf{t}

$$T_x^{(t)} = \sigma_{xx}t_x + \sigma_{yx}t_y$$

$$T_y^{(t)} = \sigma_{xy}t_x + \sigma_{yy}t_y$$

$$\begin{Bmatrix} T_x^{(t)} \\ T_y^{(t)} \end{Bmatrix} = \begin{Bmatrix} t_x & t_y \end{Bmatrix} \begin{bmatrix} \sigma_{xx} & \sigma_{xy} \\ \sigma_{yx} & \sigma_{yy} \end{bmatrix}$$

$$\sigma_{tt} = \begin{Bmatrix} t_x & t_y \end{Bmatrix} \begin{bmatrix} \sigma_{xx} & \sigma_{xy} \\ \sigma_{yx} & \sigma_{yy} \end{bmatrix} \begin{Bmatrix} t_x \\ t_y \end{Bmatrix}$$

$$\sigma_{tn} = \begin{Bmatrix} t_x & t_y \end{Bmatrix} \begin{bmatrix} \sigma_{xx} & \sigma_{xy} \\ \sigma_{yx} & \sigma_{yy} \end{bmatrix} \begin{Bmatrix} n_x \\ n_y \end{Bmatrix}$$

$$\begin{Bmatrix} \sigma_{tn} & \sigma_{tt} \end{Bmatrix} = \begin{Bmatrix} t_x & t_y \end{Bmatrix} \begin{bmatrix} \sigma_{xx} & \sigma_{xy} \\ \sigma_{yx} & \sigma_{yy} \end{bmatrix} \begin{bmatrix} n_x & t_x \\ n_y & t_y \end{bmatrix}$$

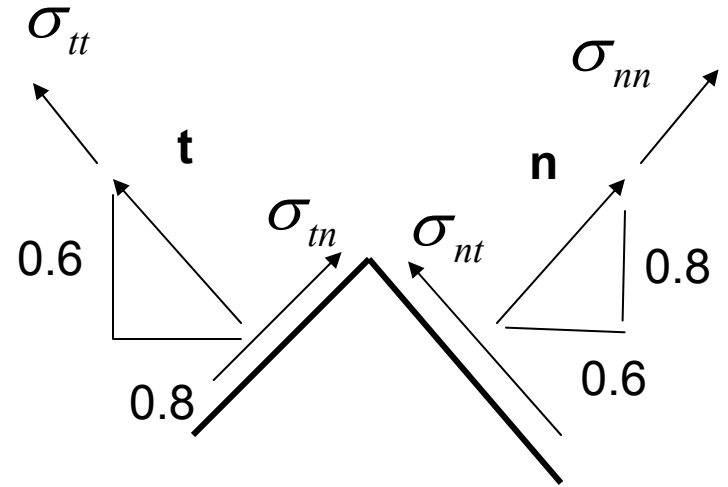

$$\{\sigma_{nn} \ \sigma_{nt}\} = \{n_x \ n_y\} \begin{bmatrix} \sigma_{xx} & \sigma_{xy} \\ \sigma_{yx} & \sigma_{yy} \end{bmatrix} \begin{bmatrix} n_x & t_x \\ n_y & t_y \end{bmatrix}$$

$$\{\sigma_{tn} \ \sigma_{tt}\} = \{t_x \ t_y\} \begin{bmatrix} \sigma_{xx} & \sigma_{xy} \\ \sigma_{yx} & \sigma_{yy} \end{bmatrix} \begin{bmatrix} n_x & t_x \\ n_y & t_y \end{bmatrix}$$

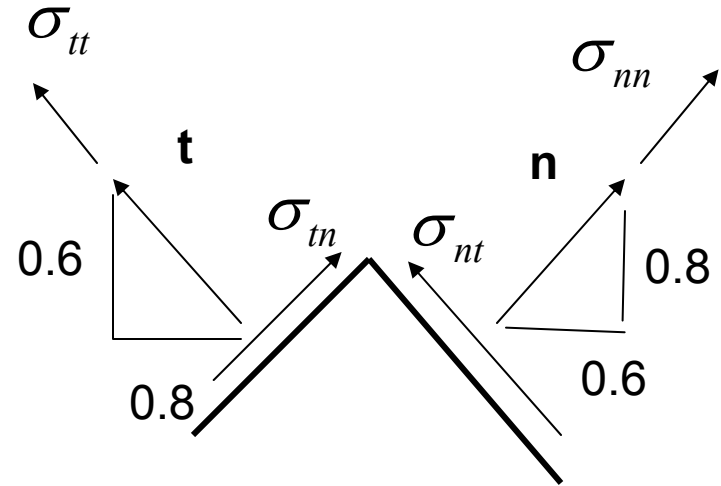

we can combine these into a single form

$$\begin{bmatrix} \sigma_{nn} & \sigma_{nt} \\ \sigma_{tn} & \sigma_{tt} \end{bmatrix} = \begin{bmatrix} n_x & n_y \\ t_x & t_y \end{bmatrix} \begin{bmatrix} \sigma_{xx} & \sigma_{xy} \\ \sigma_{yx} & \sigma_{yy} \end{bmatrix} \begin{bmatrix} n_x & t_x \\ n_y & t_y \end{bmatrix}$$

stress transformation equations

MATLAB

```
>> new_stresses = dirs'*stress*dirs
new_stresses =
    27.2000    10.4000
    10.4000    62.8000
```

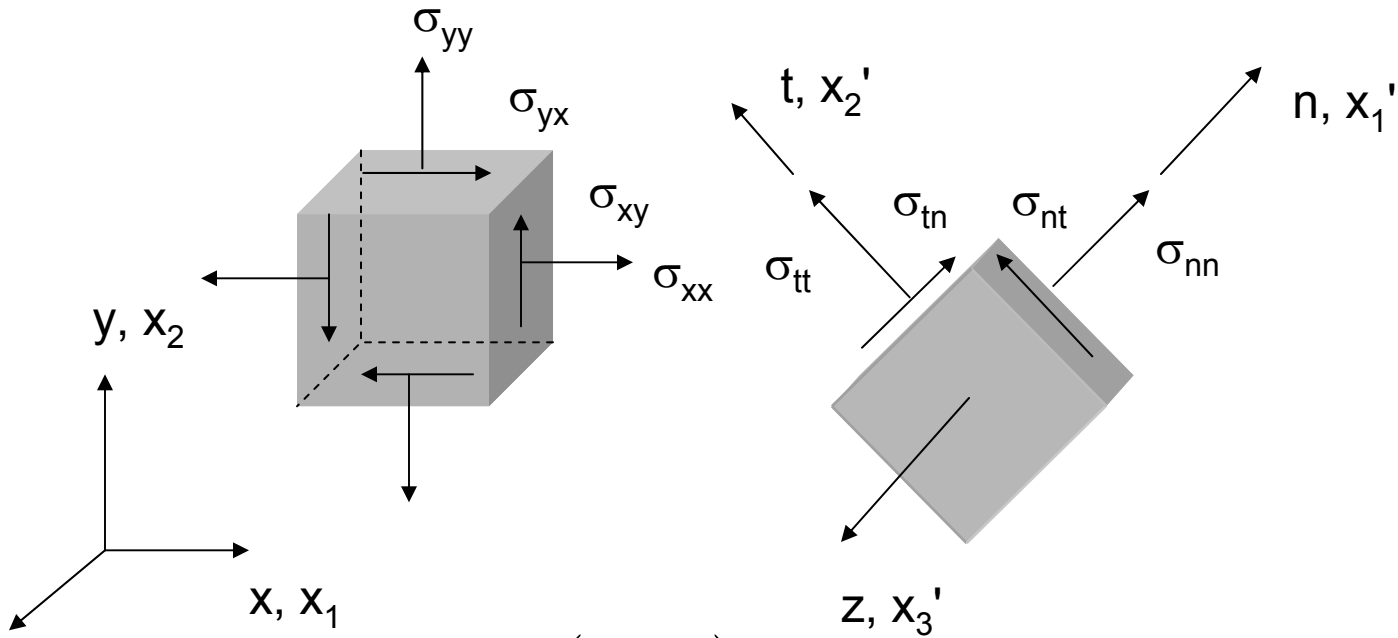

Let $l_{ij} = \cos(x'_j, x_i)$

direction cosines

then

$$n_x = \cos(x'_1, x_1) = l_{11}$$

$$n_y = \cos(x'_1, x_2) = l_{21}$$

$$t_x = \cos(x'_2, x_1) = l_{12}$$

$$t_y = \cos(x'_2, x_2) = l_{22}$$

and we have

$$\begin{bmatrix} \sigma_{nn} & \sigma_{nt} \\ \sigma_{tn} & \sigma_{tt} \end{bmatrix} = \begin{bmatrix} l_{11} & l_{21} \\ l_{12} & l_{22} \end{bmatrix} \begin{bmatrix} \sigma_{xx} & \sigma_{xy} \\ \sigma_{yx} & \sigma_{yy} \end{bmatrix} \begin{bmatrix} l_{11} & l_{12} \\ l_{21} & l_{22} \end{bmatrix}$$

or $[\sigma'] = [l]^T [\sigma] [l]$