

**Math 141 Section B**  
**Summer 2007 Trigonometry Final Exam**

Instructor: Atilla Sit

Closed book, closed notes. Calculators are **NOT** allowed. Show **all of your work** in the spaces provided. There are 10 questions, total 200 points possible. Please make sure that you have all the pages before beginning and don't forget to write your name. Good luck!

**Name:**

1. (20 pts) Find the exact value of

(a)  $\csc\left(\frac{\pi}{3}\right)$

(b)  $\cot\left(-\frac{\pi}{4}\right)$

(c)  $\tan\left(\frac{4\pi}{3}\right)$

(d)  $\sec\left(\frac{9\pi}{4}\right)$

(e)  $\cos(540^\circ)$

2. (20 pts) Find the exact value of the area of the segment (shaded in the figure below) of a circle whose radius is 8 feet, formed by a central angle  $45^\circ$ .

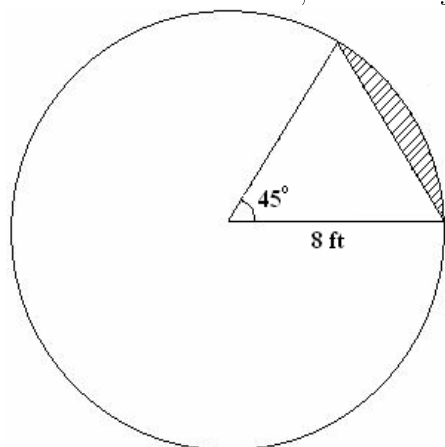

3. (30 pts) Graph the function  $y = -2 \cos \left( x + \frac{\pi}{2} \right)$  using transformations.

4. (15 pts) Solve the triangle shown below, i.e. find the exact values of  $a$ ,  $b$ , and  $\alpha$ .

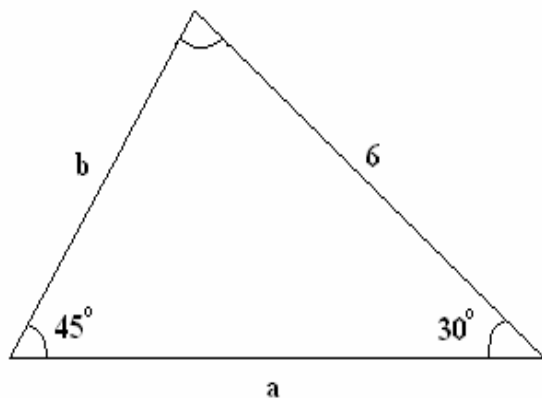

5. (15 pts) Find the exact value of each expression.

(a)  $\tan\left(2 \tan^{-1} \frac{3}{4}\right)$

(b)  $\sin 75^\circ - \sin 15^\circ$

(c)  $\sec 35^\circ \csc 55^\circ - \tan 35^\circ \cot 55^\circ$

6. (25 pts) Solve each equation on the interval  $0 \leq \theta < 2\pi$ .

(a)  $\tan\left(\frac{\theta}{2} + \frac{\pi}{3}\right) = 1$

(b)  $\sin \theta + \cos \theta = -\sqrt{2}$

7. (20 pts) Establish each identity.

(a)  $\sin \theta \cdot [\sin \theta + \sin(3\theta)] = \cos \theta \cdot [\cos \theta - \cos(3\theta)]$

(b)  $1 - \frac{1}{2} \sin(2\theta) = \frac{\sin^3 \theta + \cos^3 \theta}{\sin \theta + \cos \theta}$

(c)  $\tan^{-1} v + \tan^{-1} \left( \frac{1}{v} \right) = \frac{\pi}{2} \quad (v > 0).$

8. (20 pts) A rectangle is inscribed in a semicircle of radius 1. See the illustration:

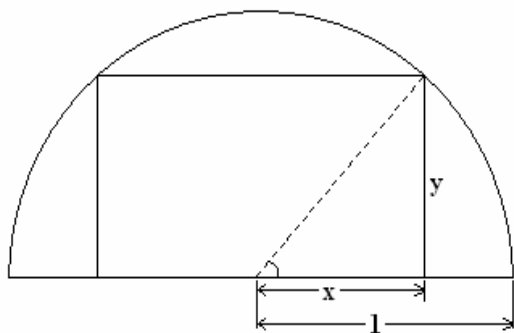

(a) Express the area  $A$  of the rectangle as a function of  $\theta$  shown in the illustration.

(b) Show that  $A = \sin(2\theta)$ .

(c) Find the angle  $\theta$  that results in the largest area.

(d) Find the dimensions of this largest rectangle.

9. (15 pts) Develop a formula for  $\cos(3\theta)$  as a third-degree polynomial in the variable  $\cos\theta$ .

10. (20 pts) For a triangle with sides  $a, b, c$ , and opposite sides  $\alpha, \beta, \gamma$ , respectively,

(a) Show that 
$$\frac{\cos \alpha}{a} + \frac{\cos \beta}{b} + \frac{\cos \gamma}{c} = \frac{a^2 + b^2 + c^2}{2ab}.$$

(b) If  $h$  is the altitude drawn from a vertex to the opposite side  $a$ , then show that 
$$h = \frac{a \sin \beta \sin \gamma}{\sin \alpha}.$$